



Artisan Scientific

Looking for more information?

Visit us on the web at www.artisanscientific.com

...the most significant ...
...the most significant ...
...the most significant ...

...the most significant ...
...the most significant ...
...the most significant ...

...the most significant ...
...the most significant ...
...the most significant ...



Release History

Part Number	Release	Publication Date
09934422	A	August 2000
	B	September 2000

User Assistance
PerkinElmer Ltd
Post Office Lane
Beaconsfield
Buckinghamshire
HP9 1QA

Printed in the United Kingdom.

Notices

The information contained in this document is subject to change without notice. PerkinElmer makes no warranty of any kind with regard to the material, including, but not limited to, the implied warranties of merchantability and fitness for a particular purpose. PerkinElmer shall not be liable for errors contained herein for incidental consequential damages in connection with furnishing, performance or use of this material.

Copyright Information

This document contains proprietary information that is protected by copyright. All rights are reserved. No part of this publication may be reproduced in any form whatsoever or translated into any language without the prior, written permission of PerkinElmer, Inc.

Copyright © 2000 PerkinElmer, Inc.

Trademarks

Registered names, trademarks, etc. used in this document, even when not specifically marked as such, are protected by law.

UV WinLab is a trademark of PerkinElmer, Inc.
PerkinElmer is a registered trademark of PerkinElmer, Inc.

Contents	3
Warnings and Safety Information	7
Safety Information	9
Safety Information in the Handbook	9
IEC 61010 Compliance	9
CSA Compliance	9
Electrical Protection	9
Electrical Safety	10
EMC Compliance	13
EC Directive	13
FCC rules and regulations	13
Environment	14
Lifting the Lambda 25, 35, 45	17
Labels	18
Introduction	21
About this Manual	23
Conventions Used in this Manual	24
Definitions	24
Notes, cautions and warnings	24
Other Warnings used in this Manual	27
System Description	35
Introduction	37
Features	37
Optical System of the Lambda 25, 35, 45	38
Lambda 25 Specification	41
General	41
Optics	42
Abscissa	42
Ordinate	43
Data Output	44
Lambda 35 Specification	45
General	45
Optics	46
Abscissa	46
Ordinate	47

Lambda 45 Specification	49
General	49
Optics.....	50
Abscissa.....	50
Ordinate	51
Data Output	52
Installation.....	53
Preparing the Working Area	55
Equipment Provided	57
Spectrometer.....	57
Components	57
Unpacking your Instrument	58
Unpacking and Inspection	58
Connecting to the Electrical Supply	59
Setting up the PC	60
Connecting the PC to the spectrometer	60
Installing UV WinLab	60
Startup and Shutdown.....	61
Startup	61
Shutdown.....	62
Installing the Single Cell Holder	63
Description	63
Accessories.....	71
Accessory Installation.....	73
Accessory Connector Panel	74
Accessory Connections Overview	76
Sample Compartment Cover	76
Sample Compartment Front Cover.....	77
Sample Compartment Window	77
Linear Transporter	78
Installation Overview	78
Temperature Sensor.....	79
Installation Overview	79
Multisippers	80
Installation Overview	80
Autosampler	81
Operating with Accessories	82
General	82

Accessories	82
Requirements for Operation with Accessories	83
Maintenance	85
Maintenance.....	87
Obtaining Service	87
Daily Care.....	87
Cleaning the Sample Compartment	88
Use and Care of Cells	90
Cell Handling.....	90
Pressure Buildup in Cells	91
Replacing a Lamp	92
Halogen Lamp Replacement	93
Deuterium Lamp Replacement.....	96
Lamp Energy Attenuator	99
Lamp Alignment Procedure.....	101
Changing Fuses.....	102
Replacement Parts	104
Analytical Notes	105
Unusual Samples	107
Volatile Samples.....	107
Samples not Governed by the Beer-Lambert Law	107
Chemically Reactive Samples	108
Photoactive Samples.....	108
Other Sample Properties.....	108
Solvent Properties.....	109
Index	111
Index	113





Pollution Degree: The equipment will operate safely in environments that contain non-conductive foreign matter and condensation up to Pollution Degree 2 - usually only non-conductive atmospheric pollution of the equipment occurs; occasionally, however, a temporary conductivity caused by condensation must be expected.

To ensure satisfactory and safe operation of the instrument, it is essential that the green/yellow lead of the line power cord is connected to true electrical earth (ground).

If any part of the instrument is not installed by a PerkinElmer service representative, make sure that the line power plug is wired correctly:

Terminal	Cord Lead Colors
-----------------	-------------------------



WARNING

Any interruption of the protective conductor inside or outside the instrument or disconnection of the protective conductor (earth/ground) terminal is likely to make the instrument dangerous. Intentional interruption is prohibited.

- *Even with the power switch OFF, line power voltages can still be present within the instrument.*
- *When the instrument is connected to line power, terminals may be live, and opening covers or removing parts (except those to which access can be gained without the use of a tool) is likely to expose live parts.*
- *Capacitors inside the instrument may still be charged even if the instrument has been disconnected from all voltage sources.*

Connect the instrument to a correctly installed line power outlet that has a protective conductor (earth/ground).

Do not attempt to make internal adjustments or replacements except as directed in this handbook.

Do not operate the instrument with any covers or parts removed.

Servicing should be carried out only by a PerkinElmer service representative or similarly authorized and trained person.

Disconnect the instrument from all voltage sources before opening it for any adjustment, replacement, maintenance, or repair. If, afterwards, the opened instrument must be operated for further adjustment, maintenance, or repair, this must only be done by a skilled person who is aware of the hazard involved.

Use only fuses with the required current rating and of the specified type for replacement. Do not use makeshift fuses or short-circuit the fuse holders.

Whenever it is likely that the instrument is no longer electrically safe for use, make the instrument inoperative and secure it against any unauthorized or unintentional operation.

The instrument is likely to be electrically unsafe when it:

- Shows visible damage;
- Fails to perform the intended measurement;
- Has been subjected to prolonged storage under unfavorable conditions;
- Has been subjected to severe transport stresses.



WARNING

If the equipment is used in a manner not specified herein the protection provided by the equipment may be impaired.

This product complies with the minimum immunity requirements of IEC 61326 and has been tested to the relevant parts of the following standards:

IEC 61000-4-2

IEC 61000-4-3

IEC 61000-4-4

IEC 61000-4-5

IEC 61000-4-6

IEC 61000-4-11

This product complies with EN 55011 Group 1 Class A and IEC 61000-3-2.

This product is classified as a digital device used exclusively as industrial, commercial, or medical test equipment. It is exempt from the technical standards specified in Part 15 of the FCC Rules and Regulations, based on Section 15.103(c).



This instrument is not designed for operation in an explosive atmosphere.

The instrument will operate correctly under the following conditions:

- Indoors.
- Ambient temperature +15 °C to +35 °C.
- Ambient relative humidity 20% to 80%, without condensation.
- Altitude in the range 0 m to 2000 m.

The instrument has been designed to be safe under the following environmental conditions:

- Indoor use.
- Ambient temperatures of 5 °C to 40 °C.
- A maximum ambient relative humidity of 80% for temperatures up to 31

Waste containers may contain corrosive or organic solutions and small amounts of the substances that were analyzed. If these materials are toxic, you may have to treat the collected effluent as hazardous waste. Refer to your local safety regulations for proper disposal procedures.

Deuterium lamps and other spectral lamps are maintained under reduced pressure. When you dispose of lamps that are defective or otherwise unusable, handle them correctly to minimize the implosion risk.

You should be aware of the health hazards presented by ultraviolet radiation.

- When the deuterium (U70sion8 Tw{When the deuterium)18.8(adi cducedz41 tothe,{Deu8fety)120

Labels are fixed to the Lambda 25, 35, 45 in the locations shown in Figure 1 and Figure 3.

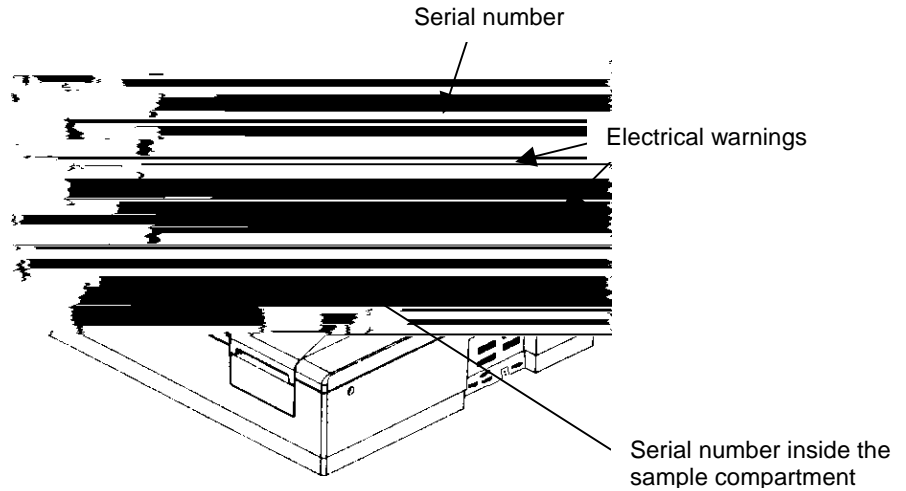

Figure 1 Labels on the spectrometer housing

The following electrical warnings are shown on the rear of the instrument:

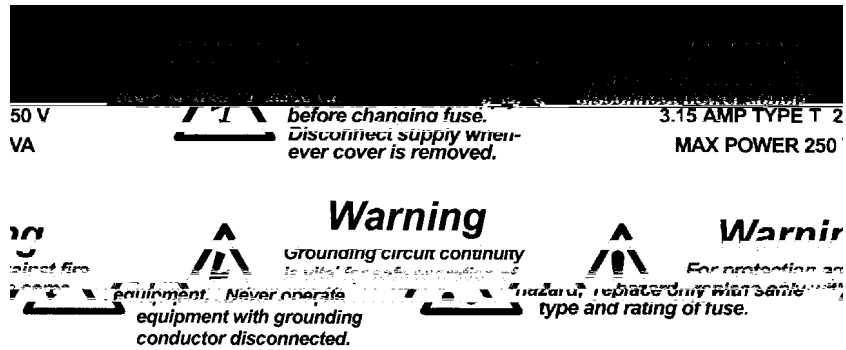

Figure 2 Warning labels on the rear of the instrument

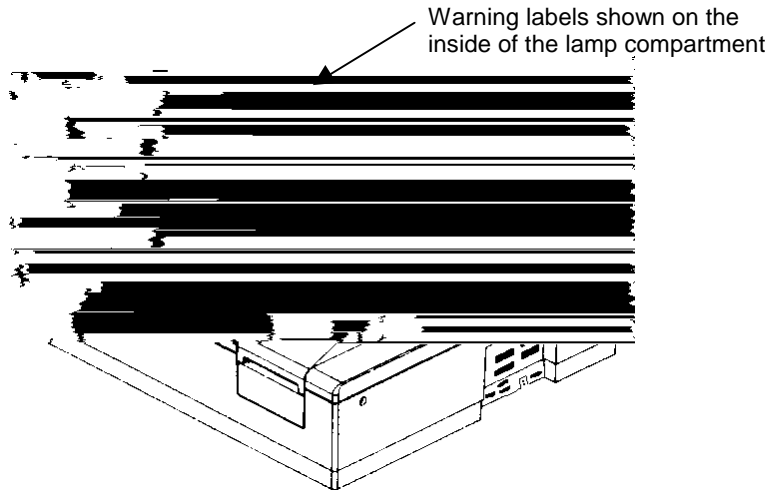

Figure 3 Lambda 25, 35, 45 Spectrometers warning labels (inside of lamp compartment)

The following warnings are shown on the inside of the lamp compartment.

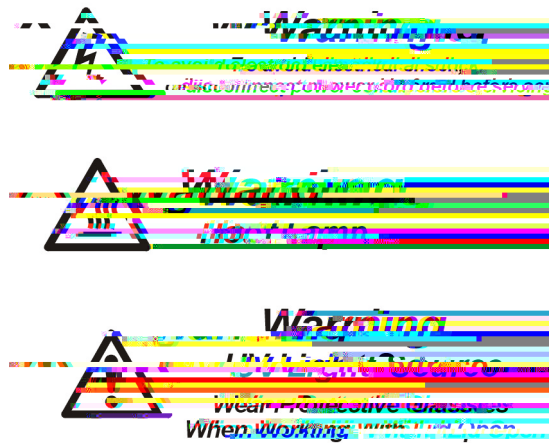

Figure 4 Warnings on the inside of the lamp compartment



Normal text is used to provide information and instructions.

text refers to text that is displayed on the screen.

UPPERCASE text, for example ENTER or ALT, refers to keys on the PC keyboard. '+' is used to show that you have to press two keys at the same time, for example, ALT + F.

CAUTION

*We use the term CAUTION to inform you about situations that could result in **serious damage to the instrument** or other equipment. Details*



WARNING

*We use the term **WARNING** to inform you about situations that could result in **personal injury** to yourself or other persons. Details about these circumstances are in a box like this one.*

Warning (Warnung)

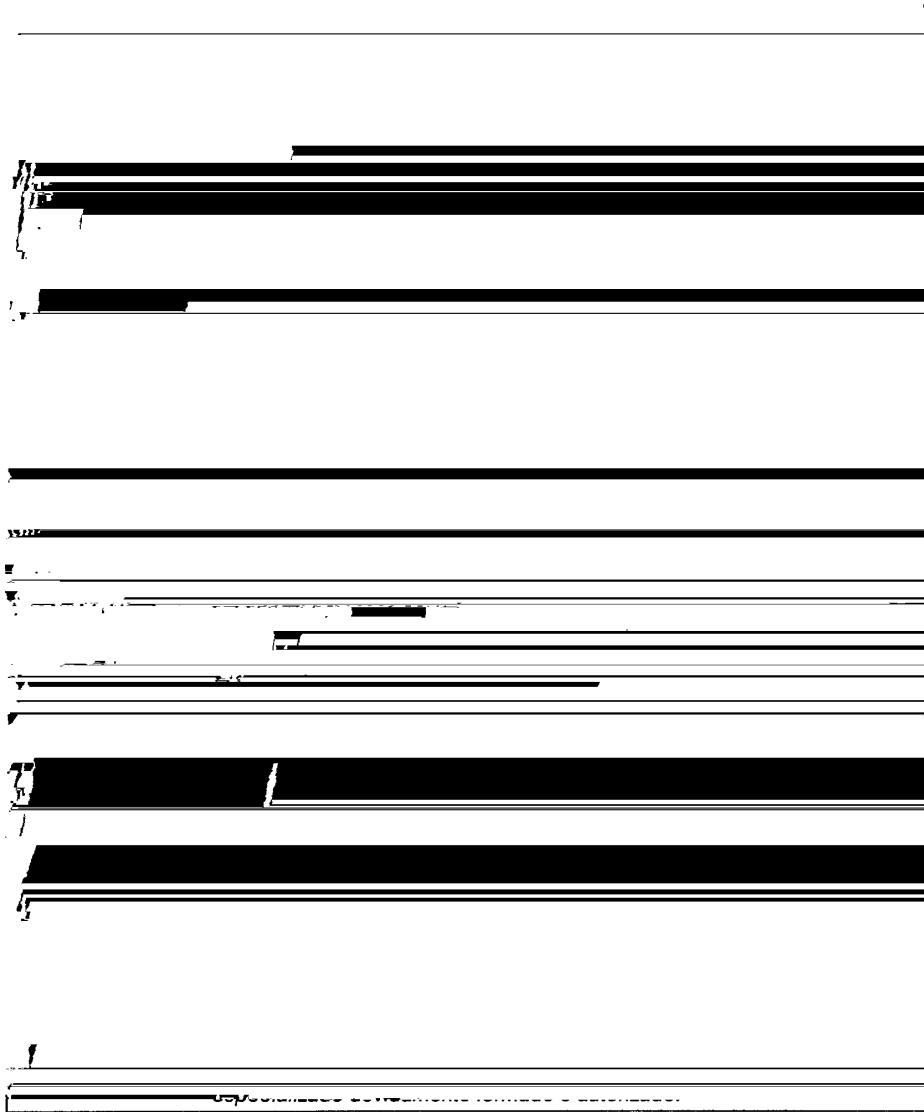

(DK)	Explosive omgivelser <i>Apparatet må <u>ikke</u> anvendes i eksplosive omgivelser!</i>
(E)	Atmósfera explosiva <i>Este aparato no ha sido diseñado para utilizarlo en atmósferas explosivas.</i>
(F)	Atmosphère explosive <i>Cet instrument n'est pas conçu pour fonctionner dans une atmosphère explosive.</i>
(I)	Atmosfera esplosiva <i>Questo strumento non è adatto per l'uso in atmosfera esplosiva.</i>
(NL)	Explosiegevaarlijke omgevingen <i>Het instrument mag <u>niet</u> in een explosiegevaarlijke omgeving worden gebruikt!</i>
(P)	Atmosferas explosíveis <i>O aparelho <u>não</u> pode ser utilizado em atmosferas explosíveis!</i>

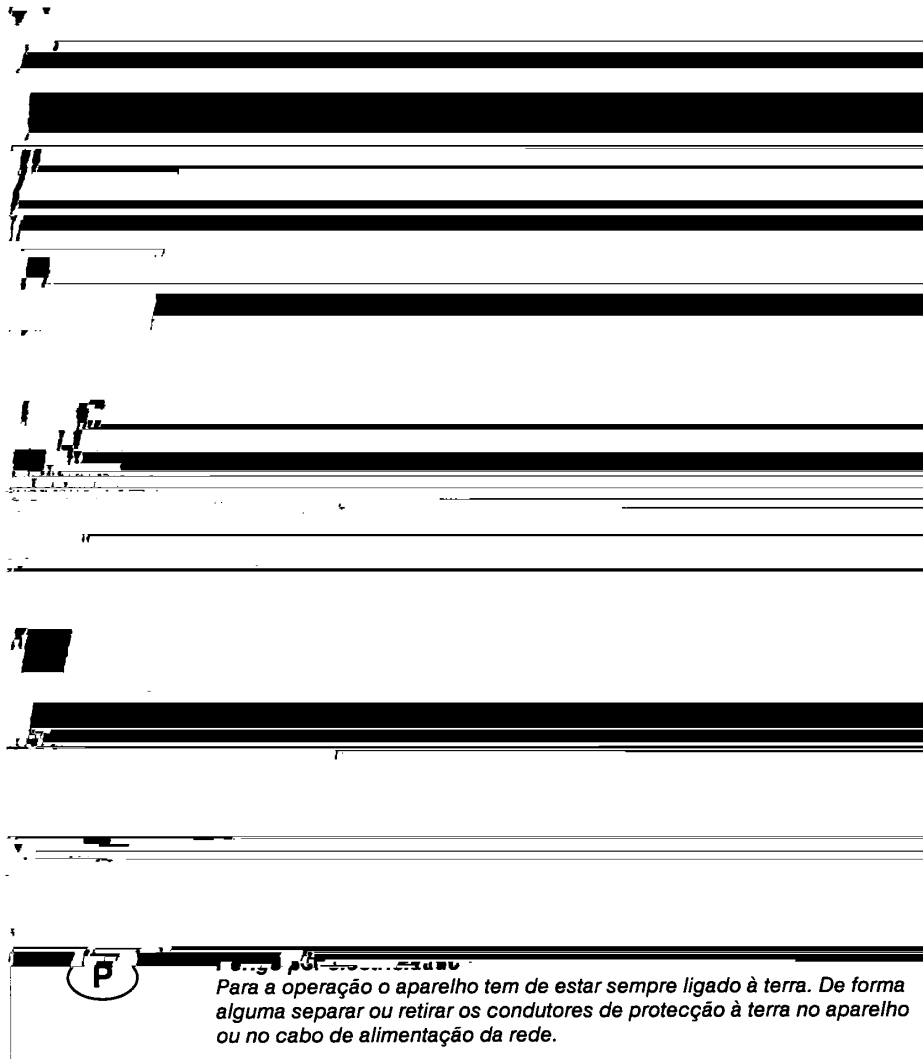

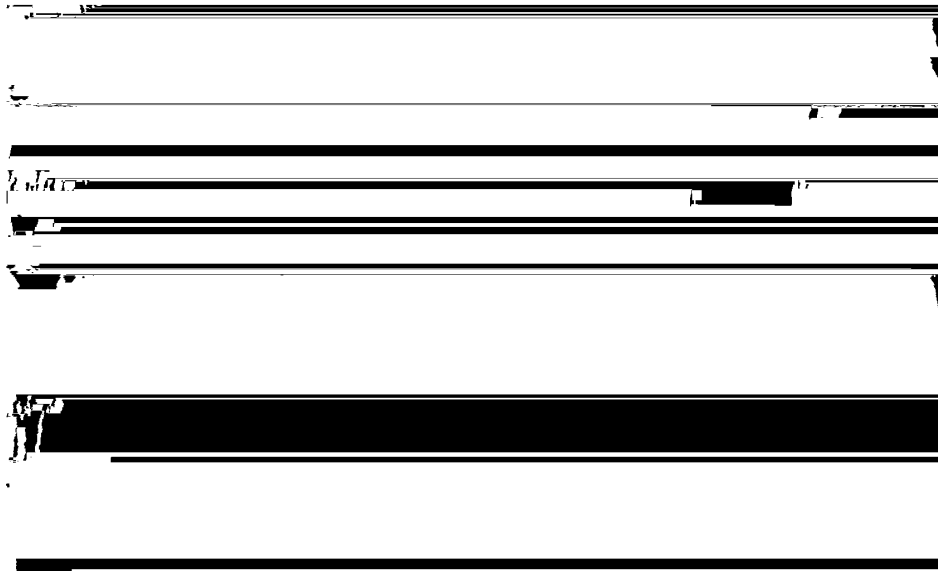

F

Prudence et consignes relatives aux tensions

- *Même lorsque l'interrupteur de puissance est sur ARRET, des tensions de secteur peuvent encore être présentes dans l'instrument.*
- *Lorsque l'instrument est relié au secteur, les raccords peuvent être sous tension, et des parties sous tension peuvent être découvertes en ouvrant des capots ou en retirant des pièces (à l'exception de celles auxquelles il est possible d'accéder manuellement).*
- *Les condensateurs contenus dans l'instrument peuvent encore être chargés, même si l'instrument a été déconnecté de toutes les sources de tension.*

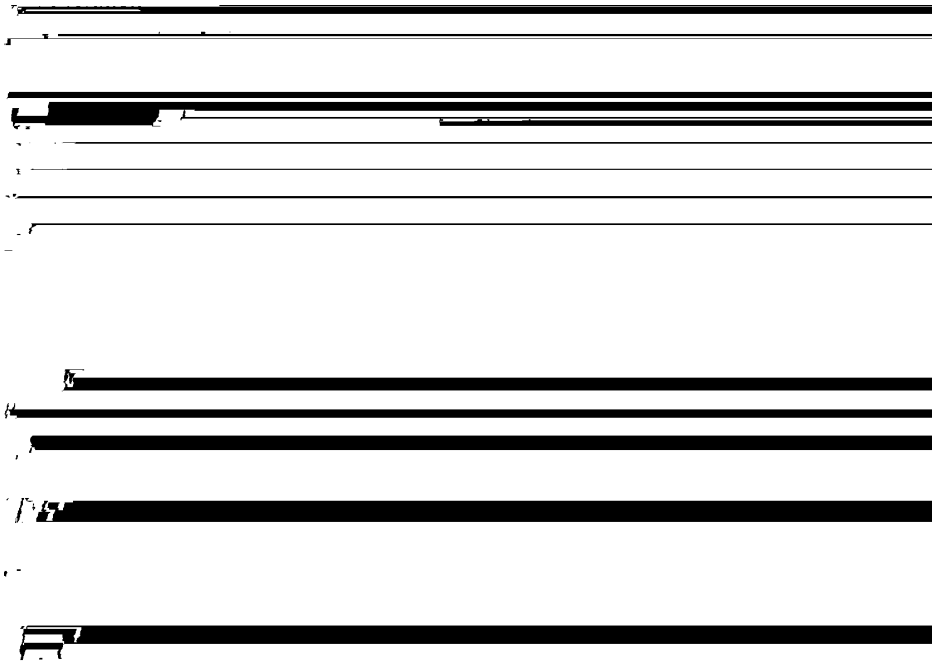

... mesmo desligado, o aparelho poderá ainda ter tensão elétrica em alguns pontos enquanto estiver ligado à rede de corrente.

- Mesmo com o aparelho desligado e a ligação à rede de corrente interrompida, os condensadores dentro do aparelho ainda poderão ter uma tensão perigosa aplicada.

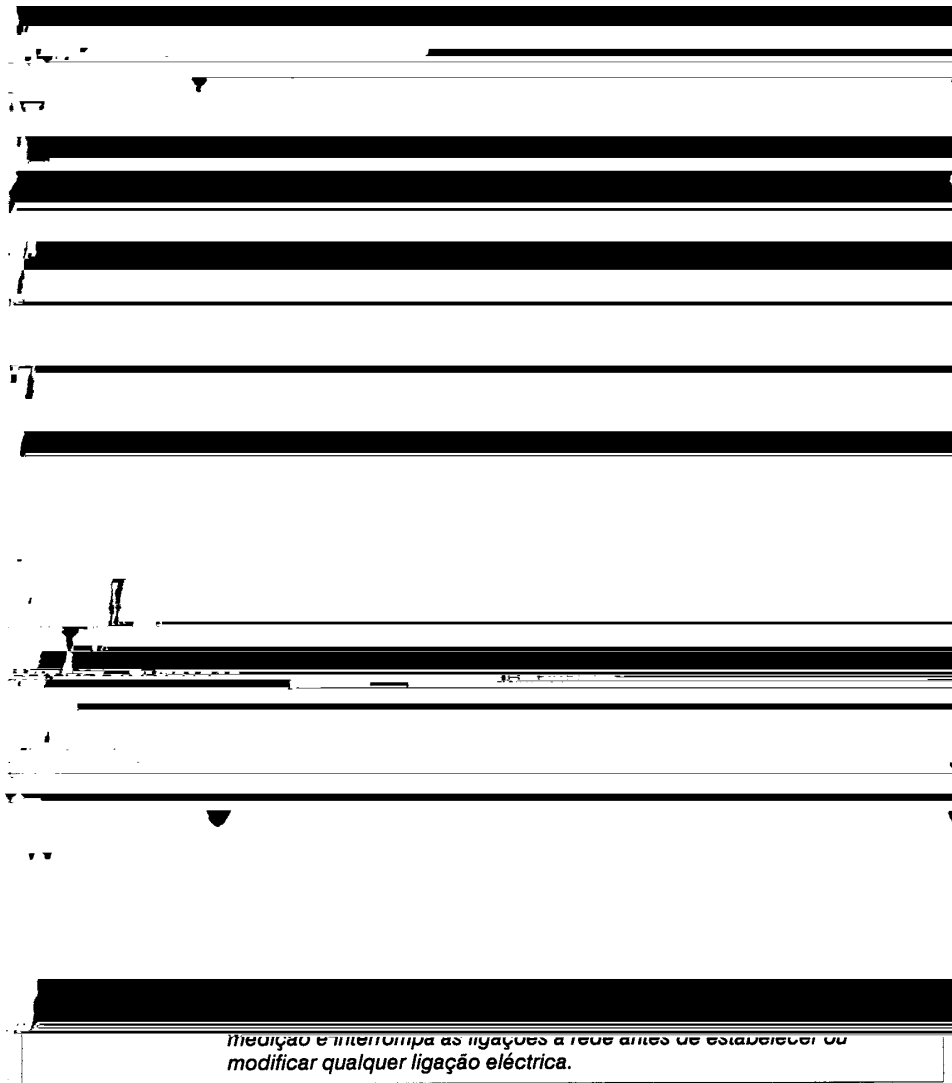

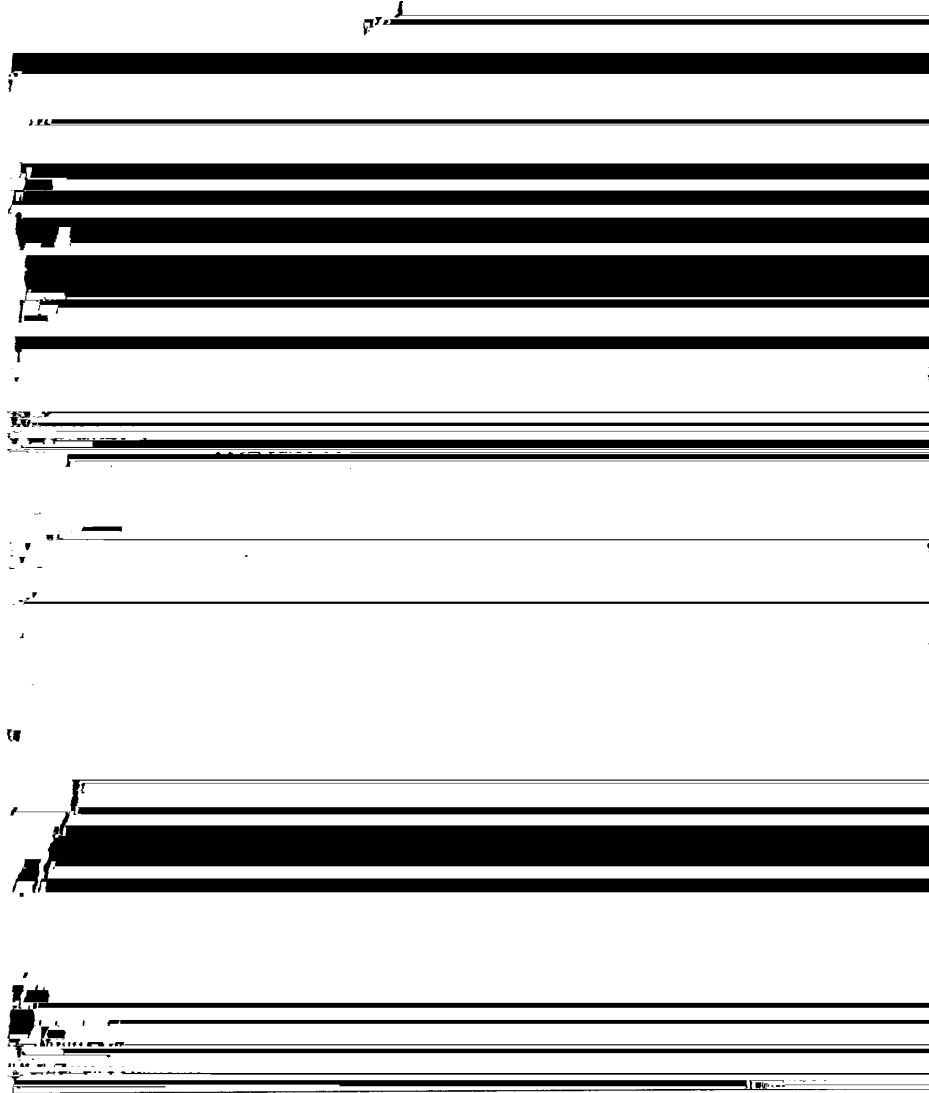





The Lambda 25, 35, 45 are versatile spectrometers operating in the ultraviolet (UV) and visible (Vis) spectral ranges. The spectrometers feature a double-beam, all-reflecting system.

Lambda 25, 35, 45 spectrometers are usable in a wide range of applications as indicated by their performance specification.

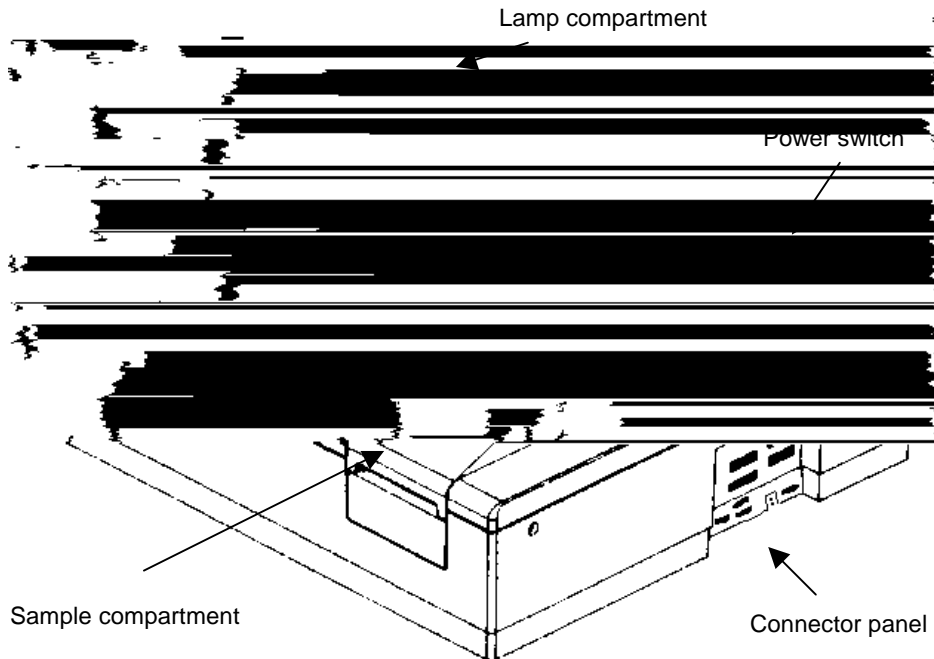

Figure 5 Lambda 25, 35, 45 Spectrometer Features

The Lambda 25, 35, 45 UV/Vis Spectrometers features an all-reflecting optical system. The optical components are coated with silica for durability. A holographic grating is used in the monochromator.

The optical system is depicted schematically in Figure 6.

The monochromator is a holographic concave grating with 1053 lines/mm in the center.

Two radiation sources, a deuterium lamp and a halogen lamp, cover the working wavelength range of the spectrometer.

For operation in the visible (Vis) range, mirror M1 reflects the radiation from the halogen lamp onto source mirror M2. At the same time M1 blocks the radiation from the deuterium lamp.

NOTE: *In the Lambda 45, M2 is substituted by a pre-monochromator grating, increasing the straylight performance of the instrument.*

For operation in the ultraviolet (UV) range, mirror M1 is raised to permit radiation from the deuterium lamp to strike source mirror M2.

Source change is automatic during monochromator slewing.

Radiation from the source lamp is reflected from source mirror M2 through an optical filter on the filter wheel assembly.

A stepping motor drives the filter wheel to be in synchronization with the monochromator.

Depending on the wavelength being produced, the appropriate optical filter is located in the beam path to prefilter the radiation before it enters the monochromator.

Filter change is automatic during monochromator slewing.

From the optical filter the radiation passes through the entrance slit (Slit 1) of the monochromator.

The radiation is dispersed at the grating to produce a spectrum. The rotational position of the grating effectively selects a segment of the spectrum, reflecting this segment through the exit slit (Slit 2) to mirror M3.

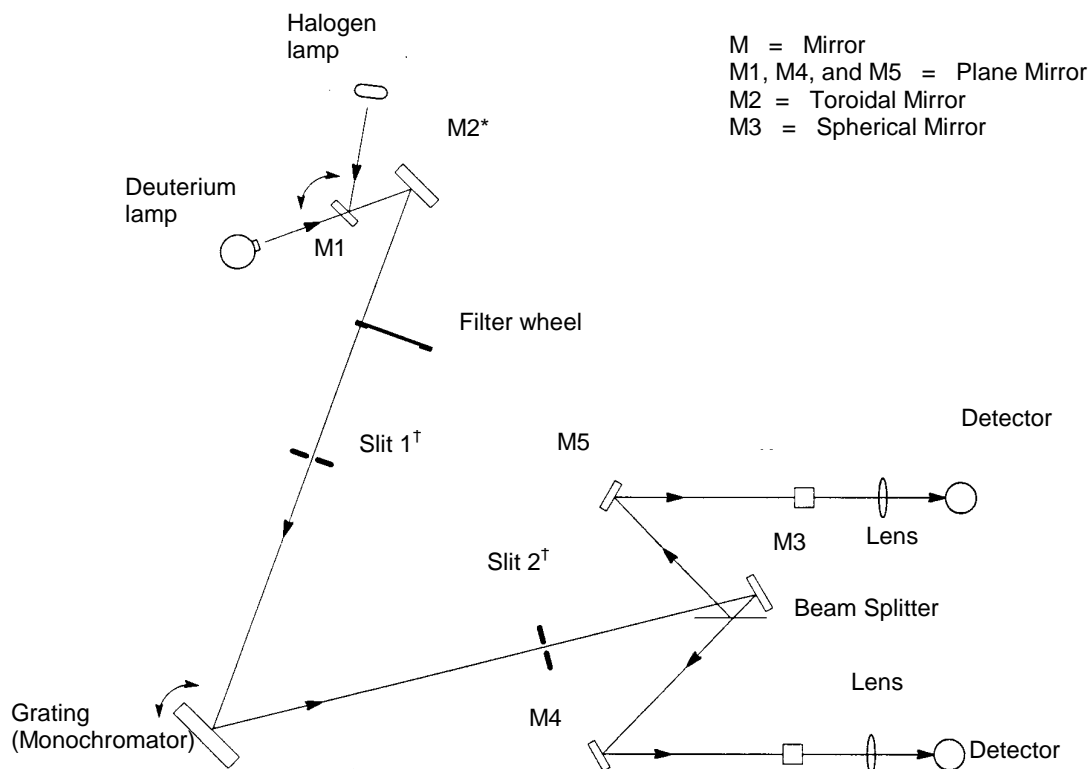

Figure 6 Optical Path for Lambda 25, 35, 45

* replaced with a pre-monochromator in the Lambda 45

† - selectable on the Lambda 35/45

Type	Scanning double-beam spectrometer for the UV/Vis range; operation by PC
Dimensions	Width: 650 mm Height: 260 mm Depth: 560 mm
Mass	26 kg approx.

Power requirements 100 V to 240 V AC, 50/60 Hz; 250 VA

Beam center height	15 mm above cell holder bottom
Beam cross-section	1 nm slit ca. 0.6 mm x 9 mm (width x height) at focal point of sample and reference beam in sample compartment
Optical pathlength in sample compartment	121 mm
Grating (Monochromator)	Holographic concave grating with 1053 lines/mm in the center
Radiation sources	Prealigned deuterium and halogen lamps
Detector	Photodiodes (One for the sample beam and one for the reference beam)

Wavelength range	190 nm to 1100 nm; 0 nm for alignment purposes
Wavelength accuracy	±0.1 nm
Wavelength reproducibility	±0.1 nm
Spectral bandwidth	1 nm (fixed slit)
Lamp change	Automatically at 326 nm (software selectable over the whole wavelength range)
Scan speeds	7.5, 15, 30 , 60, 120, 240, 480, 960, 1920 and 2880 nm/min

Photometric range	Transmission 0% to 100% Absorbance -6.000 to 6.000 (display range) 1 to 9999 (concentration units)
Photometric accuracy	Absorbance ± 0.003 (measured at Absorbance = 1 at 440 nm, 546.1 nm and 635 nm with NIST 930 filters) Absorbance ± 0.015 (measured at Absorbance = 1, at 257 nm and 350 nm with potassium dichromate solution [*])
Stray radiation	Transmission < 0.02% (at 220 nm, 340 nm and 370 nm) Absorbance > 2 (measured at 200 nm with potassium chloride solution [†])

Digital port	One RS 232 C interface (serial), for connecting a PC.
--------------	---

Type	Scanning double-beam spectrometer for the UV/Vis range; operation by PC
Dimensions	Width: 650 mm Height: 260 mm Depth: 560 mm
Mass	26 kg approx.
Power requirements	100 V to 240 V AC, 50/60 Hz; 250 VA
Ambient operating temperature	15 °C to 35 °C
Humidity range	20% to 80% relative humidity without condensation
Technical Standard	In compliance with the requirements for technical instruments stipulated by IEC 61010-1:1990 and amendments A1:1992 and A2:1995.
Radio interference suppression	In compliance with the legal requirements of the EMC directive 89.336/EEC (EN 61326)

Beam center height	15 mm above cell holder bottom
Beam cross-section	0.5 nm slit ca. 0.25 mm x 7 mm (width x height) 1 nm slit ca. 0.5 mm x 7.5 mm (width x height) 2 nm slit ca. 1 mm x 7.5 mm (width x height) 4 nm slit ca 2 mm x 7.5 mm (width x height), at focal point of sample and reference beam in sample compartment
Optical pathlength in sample compartment	121 mm
Grating (Monochromator)	Holographic concave grating with 1053 lines/mm in the center
Radiation sources	Prealigned deuterium and halogen lamps
Detector	Photodiodes (One for the sample beam and one for the reference beam)

Wavelength range	190 nm to 1100 nm; 0 nm for alignment purposes
Wavelength accuracy	±0.1 nm
Wavelength reproducibility	±0.1 nm

Spectral bandwidth 0.5 nm (at 658 nm) (one for the reference beam)

Photometric range	Transmission 0% to 100% Absorbance -6.000 to 6.000 (display range) 1 to 9999 (concentration units)
Photometric accuracy	Absorbance ± 0.003 (measured at Absorbance = 1 at 440 nm, 546.1 nm and 635 nm with NIST 930 filters) Absorbance ± 0.015 (measured at Absorbance = 1, at 257 nm and 350 nm with potassium dichromate solution [*])
Stray radiation	Transmission < 0.02% (at 220 nm, 340 nm and 370 nm) Absorbance > 2 (measured at 200 nm with potassium chloride [†] solution against distilled water)
Baseline linearity	2 nm slit: Absorbance ± 0.0005 (corrected: 200 nm to 1050 nm, scan speed 240 nm/min, smooth 2)
Baseline noise	2 nm slit: Absorbance < 0.00006 RMS, Absorbance < 0.0002 peak-to-peak 3 min at Absorbance = 0, wavelength 500 nm and response 2 s)
Baseline stability (drift)	Absorbance < 0.0003 per hour (500 nm, after warmup)

^{*} ($\text{K}_2\text{Cr}_2\text{O}_7$) = 60.06 $\mu\text{g}/\text{mL} \pm 0.5\%$ in sulfuric acid $c(\text{H}_2\text{SO}_4) = 0.005 \text{ mol/L}$

[†] (KCl) = 12 $\text{mg}/\text{mL} \pm 0.5\%$

Digital port	One RS 232 C interface (serial), for connecting a PC
--------------	--

Beam center height	15 mm above cell holder bottom
Beam cross-section	0.5 nm slit ca. 0.25 mm x 7 mm (width x height) 1 nm slit ca. 0.5 mm x 7.5 mm (width x height) 2 nm slit ca. 1 mm x 7.5 mm (width x height) 4 nm slit ca 2 mm x 7.5 mm (width x height), at focal point of sample and reference beam in sample compartment
Optical pathlength in sample compartment	121 mm
Grating (Monochromator)	Holographic concave grating with 1053 lines/mm in the center
Radiation sources	Prealigned deuterium and halogen lamps
Detector	Photodiodes (One for the sample beam and one for the reference beam)

Wavelength range	190 nm to 1100 nm; 0 nm for alignment purposes
Wavelength accuracy	±0.1 nm
Wavelength reproducibility	±0.1 nm

Spectral bandwidth 0.5 nm (at 658 nm) (one for the reference beam)

Photometric range	Transmission 0% to 100% Absorbance -6.000 to 6.000 (display range) 1 to 9999 (concentration units)
Photometric accuracy	Absorbance ± 0.003 (measured at Absorbance = 1 at 440 nm, 546.1 nm and 635 nm with NIST 930 filters) Absorbance ± 0.015 (measured at Absorbance = 1, at 257 nm and 350 nm with potassium dichromate solution [*])
Stray radiation	Transmission < 0.02% (at 220 nm, 340 nm and 370 nm) Absorbance > 2 (measured at 200 nm with potassium chloride [†] solution against distilled water)
Baseline linearity	2 nm slit: Absorbance ± 0.0005 (corrected: 200 nm to 1100 nm, scan speed 240 nm/min, smooth 2)
Baseline noise	2 nm slit: Absorbance < 0.00006 RMS, Absorbance < 0.0002 peak-to-peak 3 min at Absorbance = 0, wavelength 500 nm and response 2 s)
Baseline stability (drift)	Absorbance < 0.0003 per hour (500 nm, after warmup)

^{*} ($\text{K}_2\text{Cr}_2\text{O}_7$) = 60.06 $\mu\text{g/mL} \pm 0.5\%$ in sulfuric acid $c(\text{H}_2\text{SO}_4) = 0.005 \text{ mol/L}$

[†] (KCl) = 12 $\text{mg/mL} \pm 0.5\%$

Digital port	One RS 232 C interface (serial), for connecting a PC
--------------	--



For maximum stability and minimum maintenance observe the following requirements when siting the instrument:

- A firm base free from vibration.
- Enough space around and underneath the instrument for efficient air circulation.
- A constant temperature between 15 °C and 35 °C.
- Constant humidity between 20% and 80% relative humidity.
- An atmosphere free from dust and corrosive fumes.
- Keep out of direct sunlight.
Illumination with diffuse lighting is ideal.
- A suitable source of electrical power should be located in the vicinity of the instrument.
Electrical power must be available at a proper earth-grounded 3-wire electrical outlet.
- The standard sample compartment baseplates have drain holes in them to run off spilled liquids to the benchtop underneath the instrument. If required, a sheet of thick filter paper can be placed under the instrument.

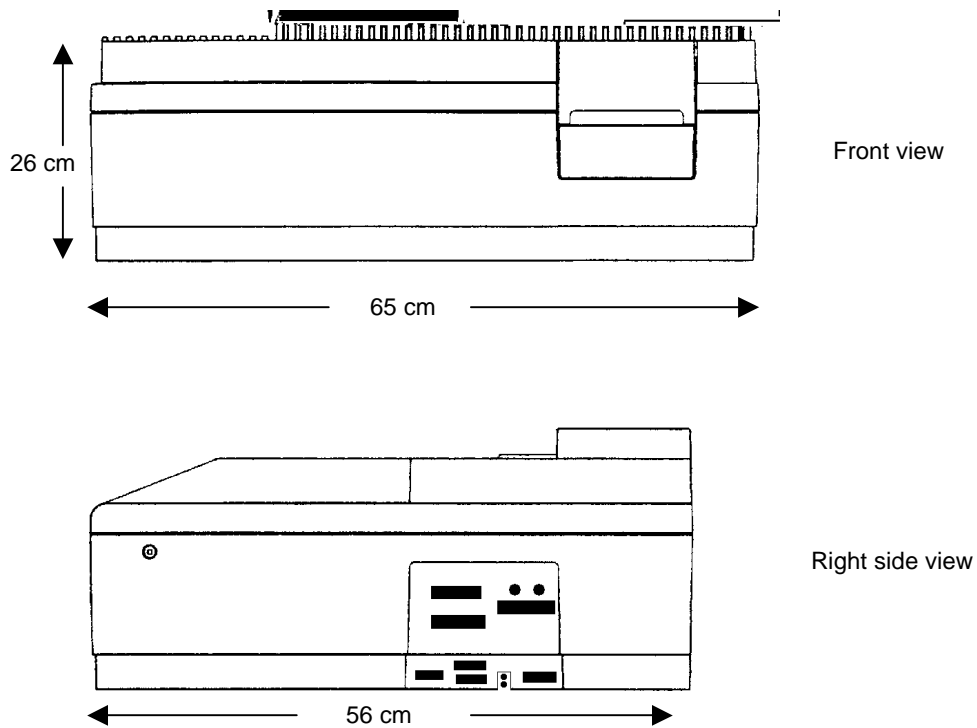

Figure 7 Space Requirements

Lambda 25 Spectrometer (Double-beam)

OR

Lambda 35 Spectrometer (Double-beam, with four selectable slit widths)

OR

Lambda 45 Spectrometer (Double-beam, with four selectable slit widths, with pre monochromator) according to order.

The components listed below are provided with the spectrometer.

1. Unpack the components carefully.
Keep the packing materials for possible future storage or reshipment.
2. Examine the components for any signs of damage in shipment.
 - Check the entire outer casing of the spectrometer for damage.
 - Make sure that terminals, fuse holders, etc. are not damaged.
 - Open and close the sample compartment cover, checking that it moves freely without binding.
 - The compartment must be free of dust or other foreign matter.

In the event of damage or missing parts, file an immediate claim with the authorized carrier, and inform your PerkinElmer office or representative.

NOTE: *PerkinElmer offers an installation service for your spectrometer. Contact your local PerkinElmer office or representative for further information.*

**WARNING**

To prevent potential injury to yourself and damage to the instrument, first make the electrical connections between the instruments in the system before connecting to the line power supply.

The spectrometer automatically adjusts to the correct operating voltage. Before starting the instrument for the first time, make sure that the correct fuse is fitted to your line power supply. If you have a different fuse, change it for the correct one. Do not connect the spectrometer to the line power supply if the wrong fuse is fitted.

1. Make sure that the correct fuses are fitted in the holder at the rear of the spectrometer (see *Changing Fuses* on page 102).

Voltage	Standard
100 V – 120 V	6.3 A slow-blow
210 V – 240 V	3.15 A slow-blow

NOTE: *The module has two fuses.*

2. Make sure that the plug fitted to the line power cord provided with the spectrometer is suitable for your local electrical outlets.
3. After all connections have been made between the various components of the system, make certain that all power switches are set to off, then connect the line cords to the electrical power supply.

The power switch is located at the top right-hand rear of the spectrometer.

NOTE: *To prevent interferences caused by earth loops when operating with ancillary instruments (autosamplers, etc.), connect all components of the system to the same phase of the electrical supply via a multisolet distributor.*

The Lambda 25, 35, 45 range requires a PC running UV WinLab version 2.85 or above.

Connect the PC to the spectrometer using the cable provided (09410022) as shown in Figure 8.



Figure 8 Connecting the PC to the spectrometer

To install UV WinLab on the PC, follow the instructions in the *UV WinLab Software User's Guide*.

Before starting analysis, leave the spectrometer switched on for approximately 10 minutes to allow the lamps to warm up and stabilize.

Wait until all initialization is complete before starting UV WinLab. This will take

1. Close down UV WinLab.
2. Switch off the accessories.
3. Open the sample compartment cover.
4. Remove samples and cells from the sample compartment.
5. If accessories (for example, flowcell) are installed in the sample compartment clean them thoroughly.
6. Close the sample compartment cover.
7. Switch off the spectrometer.

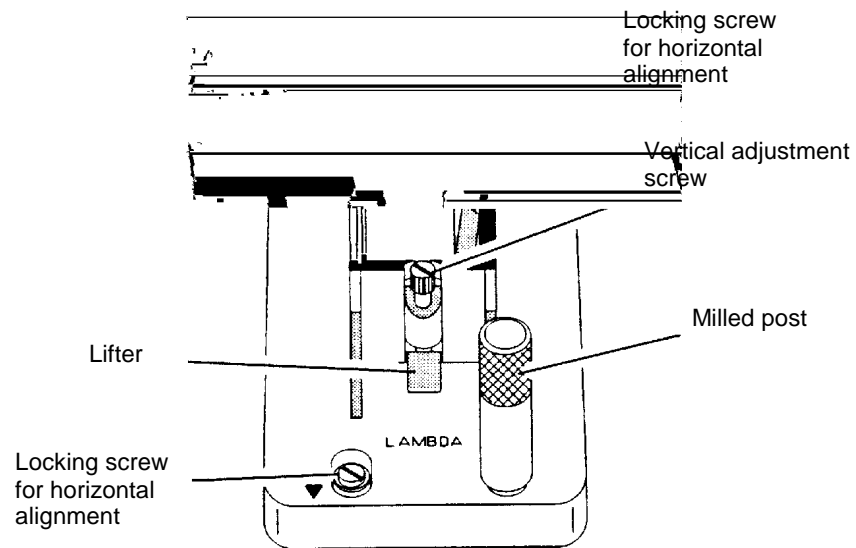

Figure 9 Single Cell Holder B0505071

Inscription legible on Holder	Use in Spectrometer
	In this position, the cell holder can be used with all Lambda Series Spectrometers.
	The cell holder should be used in this position with Lambda 25, 35, 45 Series Spectrometers. The smallest beam diameter is exactly in the middle of the cell. This is useful especially for operation with micro and semi-micro cells.

NOTE: *Depending on the spectrometer, the single cell holder can be installed in two different positions in the sample compartment. Always install the holder such that the arrow on the cell holder lines up with the center point on the baseplate.*

Install the single cell holder in the sample compartment as follows:

1. Orientate the holder so that the lifter is toward the rear of the sample compartment.
2. Lower the holder so that the two alignment holes slip onto the two studs on the baseplate at the bottom of the sample compartment.
The arrow on the cell holder must line up with the center point of the baseplate, and must be legible.

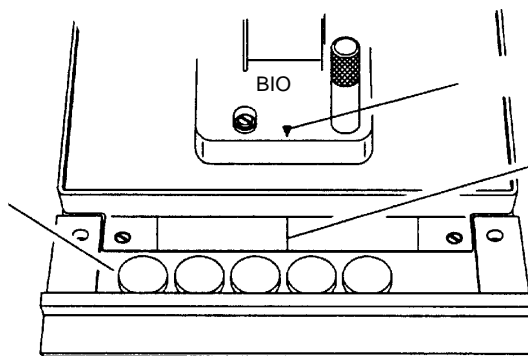

Figure 10 Installing the single cell holder

3. Move the milled posts a little to locate the threaded holes in the baseplate, and then tighten the milled posts.
The tube ports located at the front of the sample compartment allow you to lead tubes from flowcells, water-thermostatted cell holders, etc. in and out of the sample compartment.
When not in use, you should always insert the caps into the ports.

Coarse alignment of the single cell holder is carried out as follows:

1. Start the system as described in *Startup* on page 61.
2. Open the sample compartment cover.
3. Fill matching cells with a low-absorbing solvent (deionized water or ethanol).
4. Insert one cell into the sample cell holder and one into the reference cell holder.
Make certain that the cell is pushed down fully.

NOTE: *The alignment procedure is for a given cell in a given holder. After alignment, the cell should always be used in the same holder.*

5. Block the sample and reference beam window on the right hand side of the sample compartment with a card to prevent white light from saturating the detector.

3. In the UV WinLab Manual control dialog select transmission (%T) as ordinate and click .
4. Open the sample compartment cover.

To measure minimum sample volumes, use microcells (offered by PerkinElmer).

The minimum sample volume required is a function of the cell internal width or volume and is specified below.

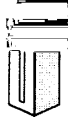
Cell Type		Cell Internal Width	Pathlength	Minimum Volume Required	Part Number
	Height of liquid slightly more than height of beam	2 mm	1 cm	200 μ L	B0631071 (pair)

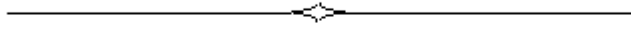



To operate the spectrometer with some accessories, for example the Peltier Temperature sensor, an accessory panel kit (L6000500) is required.

Procedures for installing the accessories in the spectrometer are described in the directions provided with the respective accessory.

To install certain accessories you need to remove the sample compartment cover. The required procedures are described below.

In the directions provided with some sample handling accessories, reference is made to earlier models in the Lambda Series of spectrometers. These directions are generally applicable to the current series of instruments since the sample compartment is standardized.

To facilitate manufacturing procedures, a common connector panel is used for the Lambda Series of instruments.

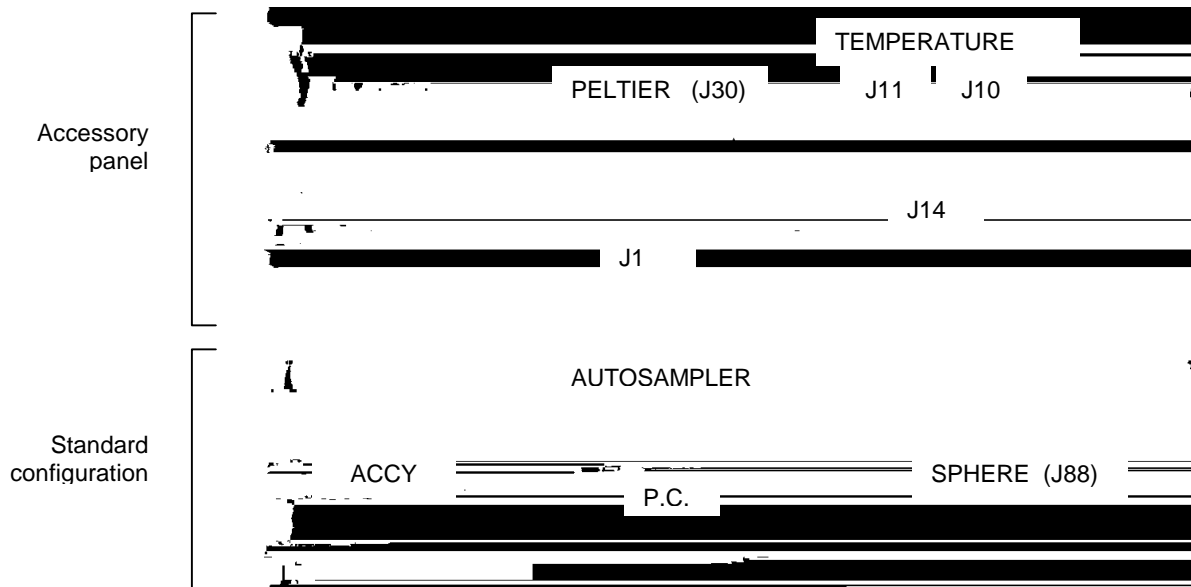

Figure 12 Accessory Connector Panel



Figure 13 Accessories for the Lambda 25, 35, 45

Some of the accessories used with the spectrometer require removal of the sample compartment cover.

Do this carefully as follows:

1. Open the cover only about 90 degrees to the sample compartment.

Some of the accessories used with the spectrometer require removal of the sample compartment front cover.

Do this carefully as follows:

1. Open the sample compartment cover.
2. Loosen the two screws securing the front cover of the sample compartment.
3. Slide the front cover forwards and remove from the spectrometer.
To install the sample compartment front cover, perform this procedure in reverse.

To remove or install certain accessories, you need to remove the sample compartment windows.

Each window has a magnetic frame and should be carefully removed by hand.



WARNING

To prevent potential injury to yourself and damage to the instrument, switch OFF all instruments in the system and disconnect them from the line power supply before you alter, or make any new, electrical connections.

Connector on Spectrometer:	
Installation:	See linear transporter manual
Cables:	Lead through bottom of spectrometer housing
Tubes:	Lead through the tube ports
Sample Compartment Cover:	Unchanged
Alignment:	See linear transporter manual

**WARNING**

To prevent potential injury to yourself and damage to the instrument, switch OFF all instruments in the system and disconnect them from the line power supply before you alter, or make any new, electrical connections.

NOTE: *When connecting the temperature sensor, align the red mark on the plug with the red mark on the socket.
Pull the collar on the plug back to connect/disconnect the plug. Release the collar to secure the plug (see Figure 12 page 74).*

Connector on Spectrometer:	
Installation:	See temperature sensor description
Cables:	Lead through the tube ports
Sample Compartment Cover:	Unchanged

The following preconditions must be fulfilled in order to operate with accessories:





All internal servicing of the instrument should be performed by a PerkinElmer service representative or similarly authorized person.

Please contact your local PerkinElmer sales or service office to obtain service.

Maintenance procedures that you can perform yourself are described in this chapter.



WARNING

*Do not attempt to make adjustments, replacements or repairs to this instrument except as described in the accompanying User Documentation.
Only a PerkinElmer service representative or similarly trained and authorized person should be permitted to service the instrument.*



WARNING

Switch off the instrument before cleaning any spilled materials.

The instrument is constructed with high quality components and requires little maintenance other than to keep it clean and free of dust.

To protect the optical system from dust and fumes, you should keep the sample compartment cover closed except for when you are carrying out work in the compartment.

You should observe the following care routine to maintain your instrument in good condition:

- Immediately clean all spilled materials from the affected area and wipe it dry with lintless paper or cloth.
If the sample compartment windows have to be wiped, make sure scratches are not introduced.
Sample windows are optical components and you should handle them in the same way as high quality cells.
- Do not leave samples, particularly those given to fuming or evaporation, in the sample compartment for longer than necessary.
- If any type of sample handling system is installed and portions of it are left in the sample compartment (such as a sipper and flowcell), make certain that the system is cleaned at the end of the working day.
Generally, such systems should be filled with deionized water when left overnight.

CAUTION

Take care not to spill liquids onto the spectrometer. Expensive damage can result to the optics or electronics if liquids are spilled and run inside the instrument or onto the keyboard.

2. Using a soft cloth and mild laboratory detergent solution, lightly scrub away all foreign material.
3. Using a clean cloth dampened with water, rinse the cleaned surfaces thoroughly.
4. Dry with lint free cloth or tissue.

Windows are provided with the spectrometer. The window is made of silica and may be used in the entire spectral range of the spectrometer.

The window seals the sample compartment and thus protects the instrument's optics from dust and fuming or aggressive samples.

- Generally, the window should be installed at all times.
- The window is an optical component and requires the same care and handling as cells.
- You can remove the window to clean it. The frame is magnetic and can be removed by hand.

Windows are most suitably cleaned by wiping them with a soft cloth moistened with ethanol.

If you are using stoppered cells, observe the following rules to prevent the buildup of internal pressure that could cause the stopper to pop-out of the cell,

- Only fill the cell so full that the liquid meniscus is just above the radiation beam. The (stop2ne-12(iwing)12.9(air space if the cell is thn adequater to stopph)2(nsaterforp)TJ ligy so that the liquid il the cellhas a chnaner toexpand.,

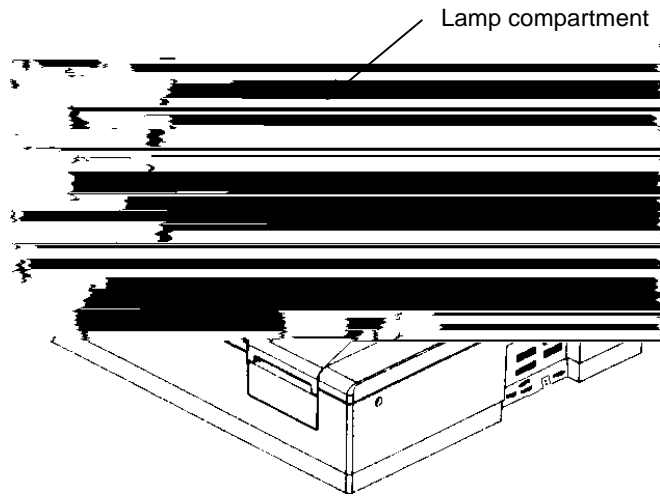

Figure 16 Lamp compartment

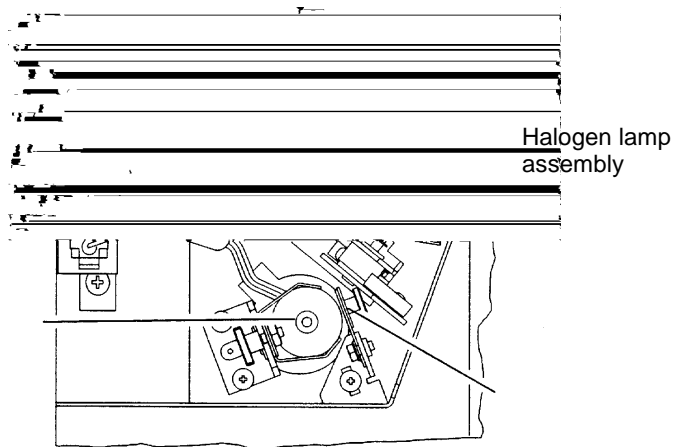

Figure 17 Inside the Lamp Compartment (Baffle removed)

If the lamp burns out, or if the bulb becomes blackened after prolonged use, you should replace the lamp.

Replacement lamp assemblies are provided complete with prealigned mounts (Part Number B0114620).

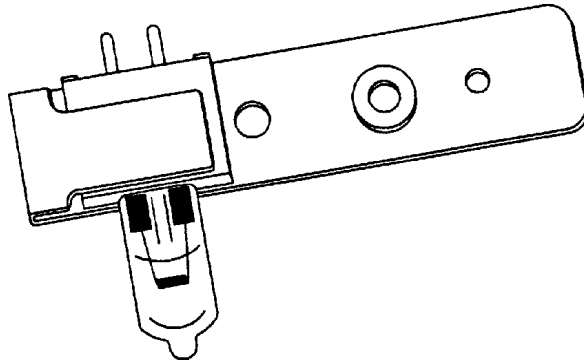

Figure 18 Prealigned Halogen Lamp (B0114620)



WARNING

Switch off the spectrometer and remove the plug from the electrical supply before starting with the replacement.

1. Switch off the spectrometer and unplug the line power cord.
2. Remove the lamp compartment cover by pressing down the catch and pushing the cover to the left.
3. Remove the lamp baffle by slackening the thumbscrew for the deuterium lamp and lifting the lamp baffle vertically upward.

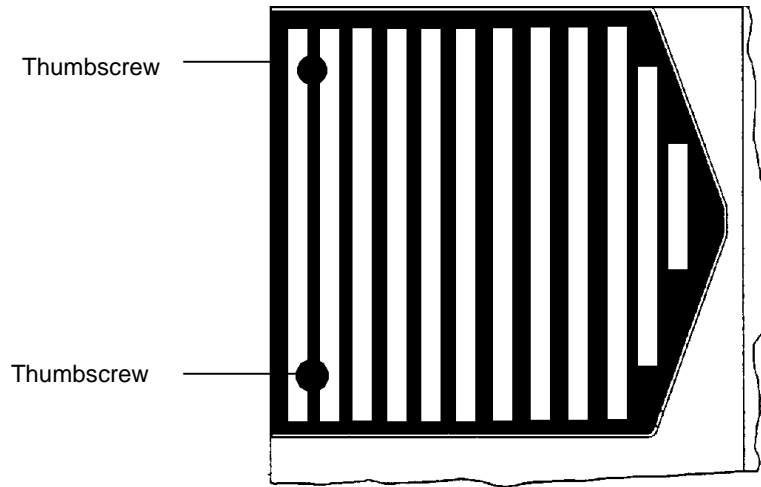

Figure 19 Lamp baffle

4. Carefully pull the white ceramic connector from the rear of the halogen lamp.

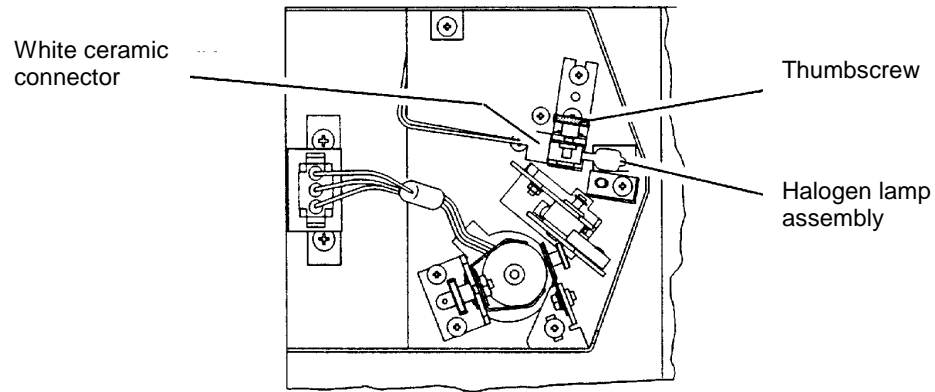

Figure 20 White ceramic connector

5. Remove the lamp assembly from the bracket by slackening the thumbscrew and pulling the lamp mount vertically upward.
Save the thumbscrew for use with the new lamp assembly.
6. Unpack the new lamp assembly, taking care to hold it only by the metal mount to prevent fingermarks on the bulb.
7. Slip the slot at the base of the lamp mount over the stud on the bracket in the lamp compartment and then secure with the thumbscrew.
8. Carefully push the ceramic connector firmly onto the pins on the base of the lamp.
9. Wipe the bulb with a soft cloth moistened with alcohol to remove dirt, since this would otherwise be burned in when the lamp is hot.
10. Replace the lamp baffle using the reverse of the procedure described in step 3.
11. Replace the lamp compartment cover.

This completes the halogen lamp replacement procedure.

If the lamp burns out, or indicates falling energy after prolonged use, you should replace the lamp.

Replacement lamp assemblies are provided complete with prealigned mounts (Part Number B0160917).

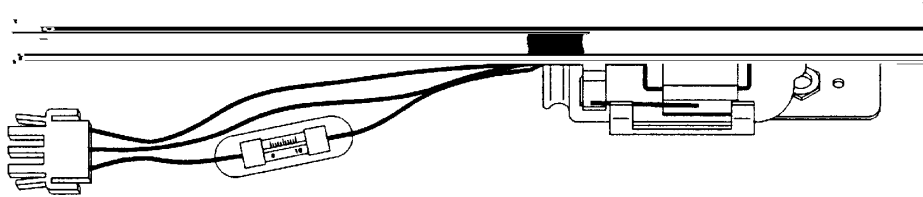

Figure 21 Prealigned Deuterium Lamp Assembly (B0160917)

NOTE:

1. Switch off the spectrometer and unplug the line power cord.
2. Remove the lamp compartment cover by pressing down the catch and pushing the cover to the left.
3. Remove the lamp baffle by slackening the thumbscrews and lifting the lamp baffle vertically upward.

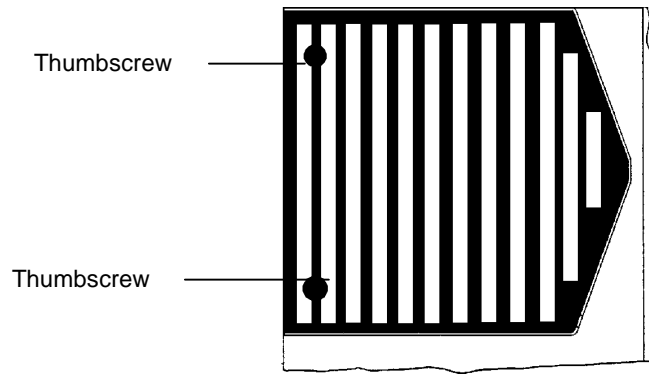

Figure 22 Lamp baffle

4. Unplug the deuterium lamp connector from the terminal board by squeezing in the two lugs at each side of the connector and carefully pulling the connector vertically upward.

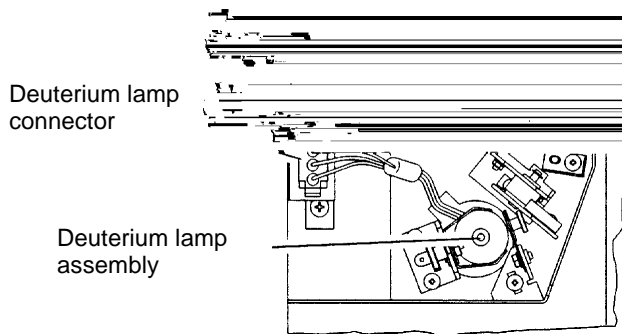

Figure 23 Deuterium lamp connector

5. Remove the lamp assembly from the bracket by slackening the thumbscrew and pulling the lamp mount vertically upward.
Save the thumbscrew for use with the new lamp assembly.
6. Unpack the new lamp assembly, taking care to hold it only by the metal mount to prevent fingermarks on the lamp window.
7. Slip the slot at the base of the lamp mount over the stud on the bracket in the lamp compartment and then secure with the thumbscrew.
8. Plug the deuterium lamp connector into the socket.

NOTE: *The socket in the lamp compartment is asymmetric; the deuterium lamp connector can be inserted in one direction only. Make certain that the connector is the right way round before inserting it. Never attempt to insert the connector by force.*

9. Wipe the lamp window with a soft cloth moistened with alcohol to remove dirt, since this would otherwise be burned in when the lamp is hot.
10. Replace the lamp baffle using the reverse of the procedure described in step 3.
11. Replace the lamp compartment cover.

This completes the deuterium lamp replacement procedure.

An attenuator is located in the lamp compartment between the deuterium lamp and the beam entrance slit.

If required you can decrease or increase the energy by placing the attenuator into, or taking the attenuator out of, the beam.

The attenuator is set at the factory, normally in the out position.



WARNING

Switch off the spectrometer and remove the plug from the electrical supply before starting with the replacement.

If the old lamp was lighted: allow it to cool before proceeding with the replacement.

*The lamps emit intense radiation which can damage your eyes.
Do not open the lamp compartment when the lamps are on.
Do not gaze into a lighted lamp.*

Operate the attenuator as follows:

1. Open the lamp compartment.
2. Remove the lamp baffle by slackening the thumbscrews and lifting the lamp baffle vertically upward.

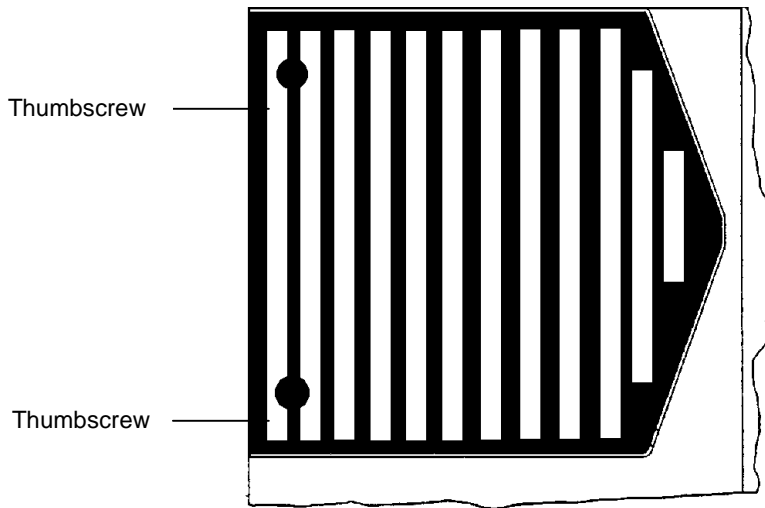

Figure 24 Lamp baffle

3. Loosen the thumbscrew holding the attenuator in place.

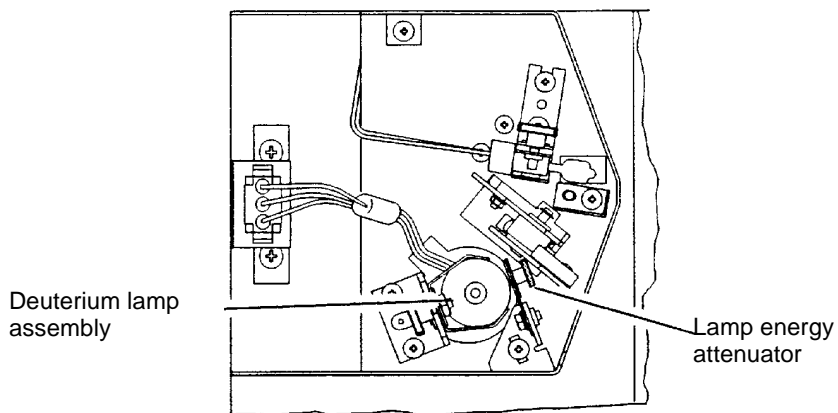

Figure 25 Deuterium lamp assembly

4. Slide the attenuator downwards into the beam.

5. Tighten the thumbscrew.

Follow the above procedure in reverse to slide the attenuator out of the beam.

3. Replace the spent fuse with a new one of the same type and rating:

Voltage	Standard
100 V – 120 V	6.3 A T
210 V – 240 V	3.15 A T

Supplies, accessories, and replacement parts can be ordered directly from PerkinElmer. e-essentials, PerkinElmer's catalog service, offers a full selection of high-quality ultraviolet, fluorescence, and polarimetry supplies through the *Supplies Catalog for Ultraviolet/Visible and Fluorescence Spectroscopy and Polarimetry*.

To place an order, request a free catalog, or ask for information:

If you are located within the U.S., call toll free **1-800-762-402**, 8 a.m. to 8 p.m. EST. Your order will be shipped promptly, usually within 24 hours.

If you are located *outside of the U.S.*, call your local PerkinElmer sales office.

Accessories, spares and other parts and information are available on-line at essentials.perkinelmer.com.

Quantity	Item	Part Number
10	3.15 A slow-blow fuse	B0155573
10	6.3 A slow-blow fuse	B0155576
1	Deuterium Lamp, prealigned	B2000501
1	Halogen Lamp, prealigned	B0114620
1	Thumbscrew for lamp mount	B0119371
1	Sample Compartment Window	B0098757
1	Single Cell Holder	B0505071



If a sample is chemically stable and undergoes no physical or chemical change other than to absorb incident radiation, errors in photometric values should not be caused by the sample. Many samples are not stable, and special consideration must be given to them.

Some liquid samples are so volatile that their concentration can change while recording is in progress. If this occurs, the resulting data will lack reproducibility.

If you are analyzing volatile samples, use stoppered cells to prevent this problem.

Quantitative analyses utilizing the absorption of spectral radiation are based on the Beer-Lambert law which states that the absorption is proportional to the concentration of the analyte.

The law can be expressed in the form

$$A = \epsilon c d$$

Where:

A is absorbance

ϵ is molar absorption coefficient

c is molar concentration

d is thickness through which the radiation is transmitted

This law is mostly true for dilute solutions, but at higher concentrations a plot of absorbance against concentration will be non-linear for a number of reasons.

The solvent should meet the following requirements:

- It should dissolve the sample without reacting with it.
- The radiation absorption in the scanning region should be low.
High absorption by the blank reduces the reference energy, thus increasing noise.
- Evaporation should be fairly low at ambient temperature.

In general, aromatic compounds exhibit high absorption in the UV region and hence are not suitable as solvents for measurements in this region.

Water is virtually the only useful solvent below 195 nm, but it must be freed from oxygen to attain best transmission.

Whenever you are going to use a solvent with unknown absorption characteristics, scan its spectrum first to determine whether it is suitable.

The lower wavelength limits of a number of commonly used solvents are presented in the following table.

The lower limit has been defined as that wavelength at which 10 mm of pure solvent has a transmission of 10%.

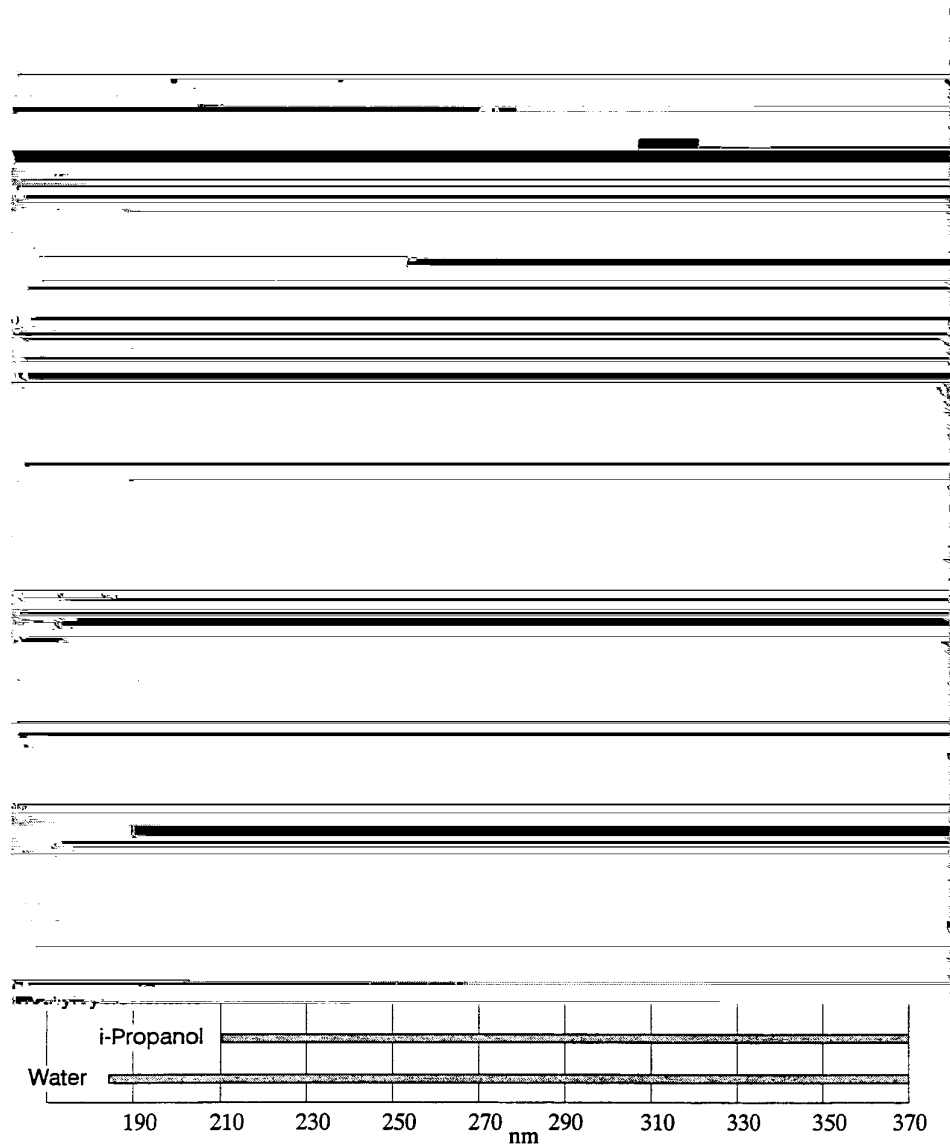
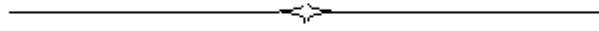

Figure 28 Lower Wavelength Limits of Solvent



A

- Accessories, 82
- Accessory Installation
 - Autosampler, 81





Artisan Scientific

Looking for more information?

Visit us on the web



The first part of the document discusses the importance of maintaining accurate records of all transactions and activities. It emphasizes the need for transparency and accountability in financial reporting. The second part of the document provides a detailed analysis of the company's performance over the past year, highlighting key areas of success and challenges. The third part of the document outlines the company's strategic vision for the future, including plans for expansion and innovation. The fourth part of the document discusses the company's commitment to social responsibility and environmental sustainability. The fifth part of the document provides a summary of the company's financial results and a forecast for the upcoming year. The sixth part of the document discusses the company's governance structure and the role of the board of directors. The seventh part of the document discusses the company's human resources strategy and its commitment to employee development. The eighth part of the document discusses the company's marketing and sales strategy and its commitment to customer satisfaction. The ninth part of the document discusses the company's legal and regulatory compliance efforts. The tenth part of the document discusses the company's overall financial health and its ability to meet its obligations to stakeholders.



The company's financial performance has been strong over the past year, with revenue increasing by 15% and profit margins improving. This is due to a combination of factors, including increased sales, cost savings, and operational efficiency. The company's strategic focus on innovation and customer satisfaction has also contributed to its success. However, there are several challenges that the company faces in the future, including increased competition, changing market conditions, and rising costs. The company's management team is committed to addressing these challenges and ensuring the company's long-term success.

The company's financial results for the year ended 31st December 2023 are as follows: Revenue of \$1.2 billion, Profit before tax of \$150 million, and Profit after tax of \$100 million. The company's financial performance is in line with the targets set in its annual budget. The company's financial health is strong, with a solid balance sheet and a low level of debt. The company's management team is confident in the company's ability to continue to grow and succeed in the future.

The company's financial performance is a reflection of the hard work and dedication of its employees. The company is committed to providing its employees with a supportive and challenging work environment. The company's management team is committed to ensuring that all employees are treated fairly and with respect. The company's financial success is a testament to the company's commitment to excellence and its dedication to its stakeholders.

The company's financial performance is a reflection of the company's commitment to its stakeholders. The company is committed to providing its shareholders with a return on their investment. The company's management team is committed to ensuring that all stakeholders are treated fairly and with respect. The company's financial success is a testament to the company's commitment to excellence and its dedication to its stakeholders.

The company's financial performance is a reflection of the company's commitment to its stakeholders. The company is committed to providing its shareholders with a return on their investment. The company's management team is committed to ensuring that all stakeholders are treated fairly and with respect. The company's financial success is a testament to the company's commitment to excellence and its dedication to its stakeholders.

The company's financial performance is a reflection of the company's commitment to its stakeholders. The company is committed to providing its shareholders with a return on their investment. The company's management team is committed to ensuring that all stakeholders are treated fairly and with respect. The company's financial success is a testament to the company's commitment to excellence and its dedication to its stakeholders.

The company's financial performance is a reflection of the company's commitment to its stakeholders. The company is committed to providing its shareholders with a return on their investment. The company's management team is committed to ensuring that all stakeholders are treated fairly and with respect. The company's financial success is a testament to the company's commitment to excellence and its dedication to its stakeholders.