

Computer Engineering Program

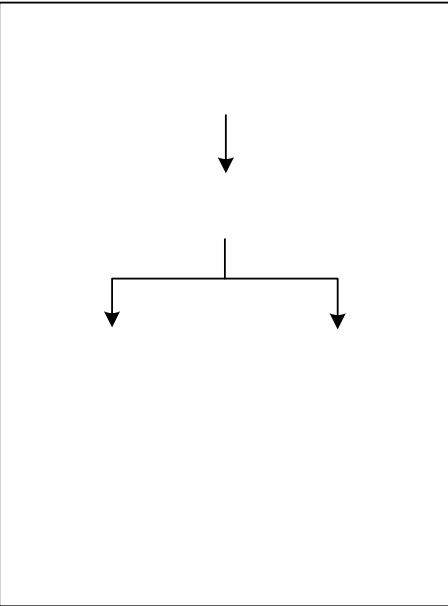

CHM05
CHM05
(hrs)
En.Chem
/lab

Natural
Science
Elective
(3 hrs)

EE 800/800L
(hrs)
**Foundations of
Engineering**

→ **ENC 1102** (3 hrs)
Composition II

PHY 2049/2049L
(4 hrs)
Physics II w/ Lab

COP 2510 (3 hrs)
Programming
Concepts

Note: COP 2510, CDA 3103,
and COP 3514 with a
minimum grade of B based
on best attempts in each
course. These requirements
must be met with a maximum
of two attempts allowed for
each course.

COT 3100 (3 hrs)
Discrete
Structures

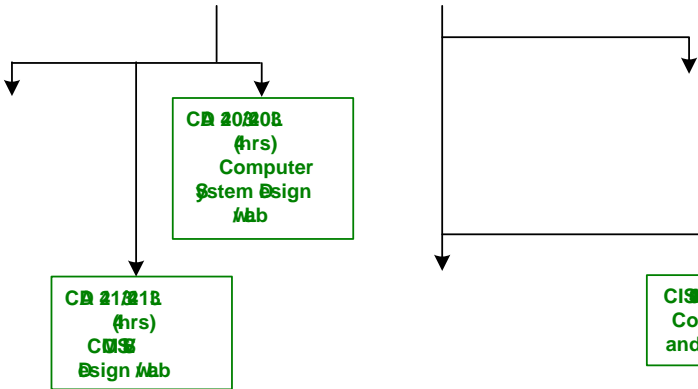
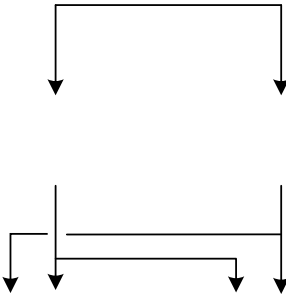

Industry internship
An industry internship is recommended for the third summer. Credit can be earned as **CIS 4940 Industry Internship**. See the Department Advisor for more information.

Notes

- 1) Unless otherwise stated, the minimum acceptable grade in all required math, science, and engineering courses is a C or higher (C- is insufficient). The minimum acceptable grade in specialization courses is a C-, except as stated in the program admission and continuation requirements in the catalog.
- 2) COP 4530 is the minimum prereq for most software electives. CDA 3201 with lab is the minimum prereq for most hardware electives. COP 4530 and COT 3100 are the minimum prereqs for theory electives. .
- 3) Department website lists elective courses by category. Should also consult with Department advisor.
- 4) Taking MAP 2302 may be best if seeking a Math minor. Should also consult with Department advisor.